



Tank Management Australia's AusTote™ stainless steel IBCs are a globally recognised, trusted and proven design. These IBCs are ISO9001 precision engineered and manufactured using heavy duty 304 grade stainless steel with fully purged welds inside and out.

The AusTote™ IBCs are UN Approved with a load rating of SG1.9, flammable rated, dangerous goods and food approved. Based on their superior design and construction, our AusTote™ IBCs are the leader for stainless steel IBCs in the Oceania region.



Product Features:

- 500 litre AusTote™ UN/Dangerous Goods Approved SG 1.9 Stainless Steel 'side drain' IBC
- 304 grade 10 gauge stainless steel. Also available in 316 grade upon request.
- 22 inch opening with EPDM seal, stainless steel manway cover (605mm), 3 inch male NPS threaded port and fusible cap
- Stainless steel locking ring with stainless steel nut and bolt
- 2 x 2 inch BSP ports in top
- Fully purged robotic welds inside and out
- Unique moulded sloped base with additional drainage channels delivering complete drainage
- 2 inch NPT stainless steel reverse stem ball valve with 316 grade ball and Teflon seals
- Combination stacking pads/leg positioners/lifting lugs
- IBCs are suitable for offshore use with slings, chains or lifting frames. The lifting lugs are designed to take the bolts and shackles etc.
- 3 way fork entry
- Optional vent/vacuum devices, camlock kits, gauges and other accessories available
- 500, 1000, 1325, 1500, 2082 and 3000 Litre sizes available



BULK ORDERS AVAILABLE

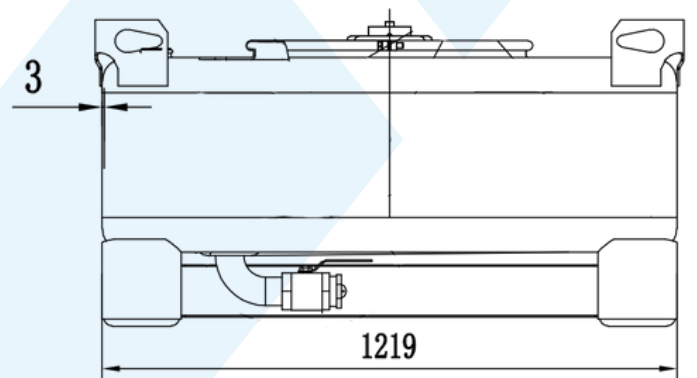
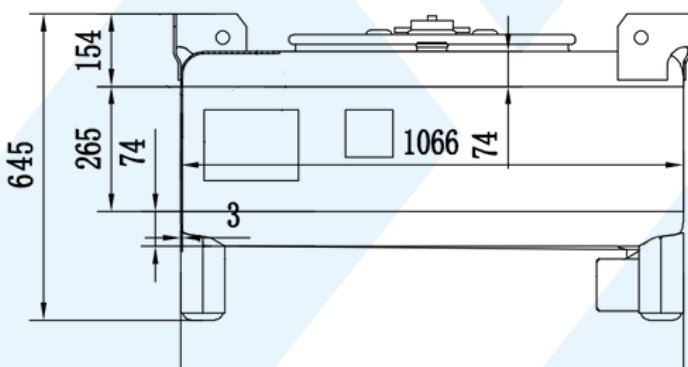
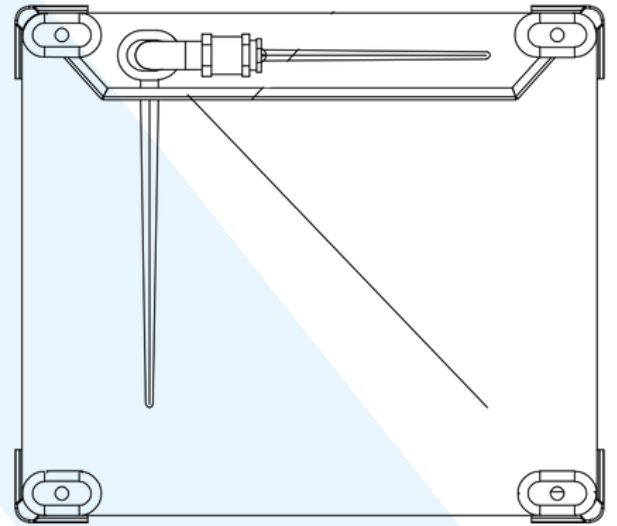
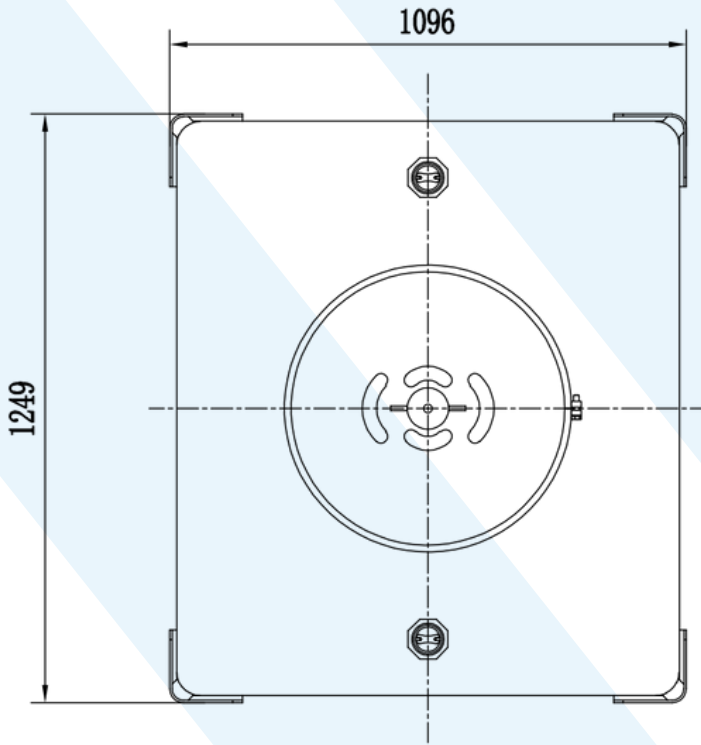

Specifications:

- Dimensions: 1249L x 1096W x 645H
- Weight: 105 Kgs